

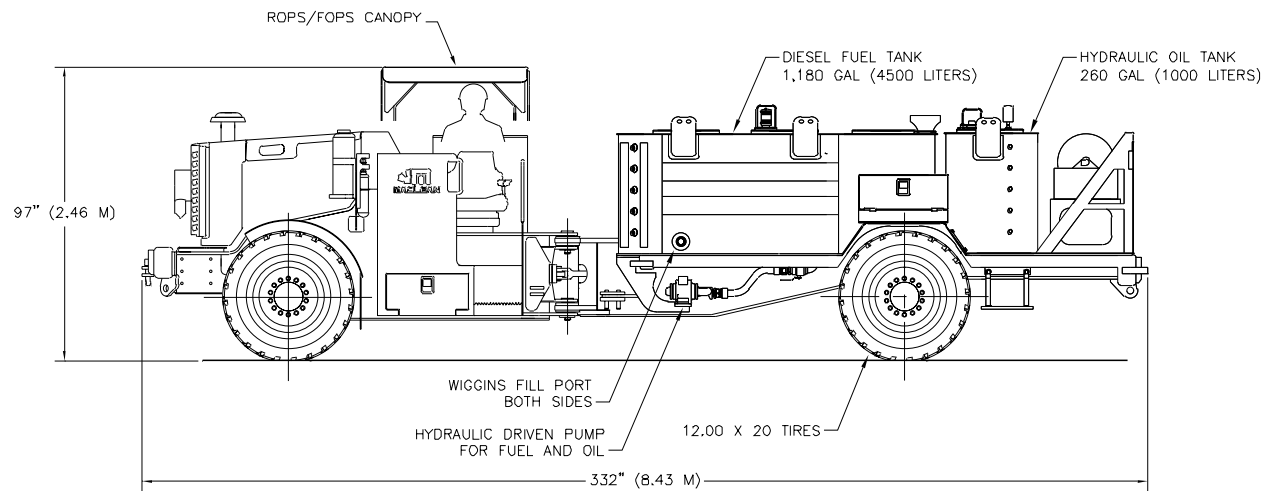

performance • reliability • innovation

## Mine-Mate™ Series

# FL-3 Fuel-Lube Truck

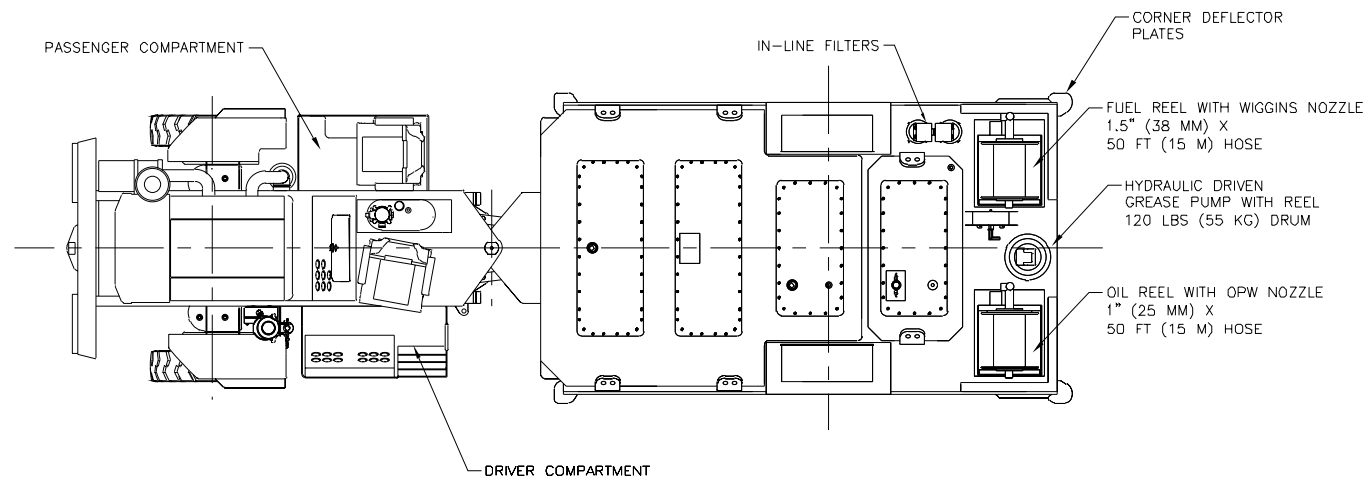

Typical configuration, subject to change based on customer requirements  
Shown with optional equipment included

### Weights and Dimensions

Empty vehicle weight: 35,000 lbs (15,900 kg)  
Width: 96" (2.44 m)  
Length: 332" (8.43 m)  
Tramming height: 97" (2.46 m)

+/- 40 degrees steering angle  
Inside turning radius: 227" (5.77 m)  
Outside turning radius: 337" (8.56 m)



[www.macleanengineering.com](http://www.macleanengineering.com)

### Sales and Product Support

1067 Kelly Lake Road  
Sudbury, Ontario Canada P3E 5P5

Main Office: +705.670.8014  
Customer Service: 1.866.856.3626  
Facsimile: +705.670.8023  
Email: [sales@macleanengineering.com](mailto:sales@macleanengineering.com)

MacLean Engineering designs, develops, and supplies specialty equipment to meet the needs of the mining industry. We provide "best in class" product support that includes commissioning, training and after sales service.

# Resource-full.



## Features

- Up to 1,500 US gallons (6,000 Litres) carrying capacity of diesel fuel, oils, grease and lubricants
- Heavy duty tanks with baffles and clean out covers
- Manual and/or “Wiggins” fill ports
- Manual (OPW) or “Wiggins” discharge nozzles
- Spring or hydraulic retract reels
- Dependable hydraulic driven pumps
- Clean high powered, electronically controlled engines
- Reliable, proven power train components
- Four wheel drive, articulated steer carrier
- Canopy and enclosed cab option

# FL-3 Fuel-Lube Truck

Today’s fast track mining methods require the timely supply of diesel fuel, oils and lubricants. Productivity of diesel-hydraulic and electrical-hydraulic equipment is only achievable if energy sources are made readily available. The Mine-Mate™ FL-3 Fuel-Lube Truck is an integral member of the bulk materials transfer system.



## The MacLean Advantage:

- ➔ Self loading / unloading capability
- ➔ Long life power train using industry proven components
- ➔ Clean burning, fuel-efficient engine minimizes harmful emissions
- ➔ Low cost, dependable mine supply vehicle
- ➔ Ease of maintenance with electronic engine diagnostics, accessible fuel filling and grease points
- ➔ Superior traction due to four wheel drive and Powershift transmission

## Applications

- The FL-3 is a rugged and dependable means of transferring and dispensing bulk fluids. Flexibility and maneuverability allow the vehicle to service fueling stations or deliver direct to vehicles in remote locations.
- Transportation between surface and underground levels via internal ramp network